

-3/QTY.	-1/QTY	ITEM	PART NUMBER	Description	SPEC
2	2	10	MS24693-C24	FLAT HEAD, 100 DEG, #6-32 X 0.25	
1	1	9	E04_07_018_0_01	CABLE CARRIER	△2
1		8	3545176-3	MONITOR ASSEMBLY	
	1	7	3545176-1	MONITOR ASSEMBLY	
1	1	6	3545173-1	GAS SPRING ASSEMBLY	
1		5	3545170-3	SLIDE ASSEMBLY	
	1	4	3545170-1	SLIDE ASSEMBLY	
1		3	3545164-3	MAIN PANEL ASM	
	1	2	3545164-1	MAIN PANEL ASM	
2	2	1	3502295-10	RETAINER	

REV.	DATE	DESCRIPTION
IR	12/12/08	INITIAL RELEASE
A	02/03/10	-3 ADDED

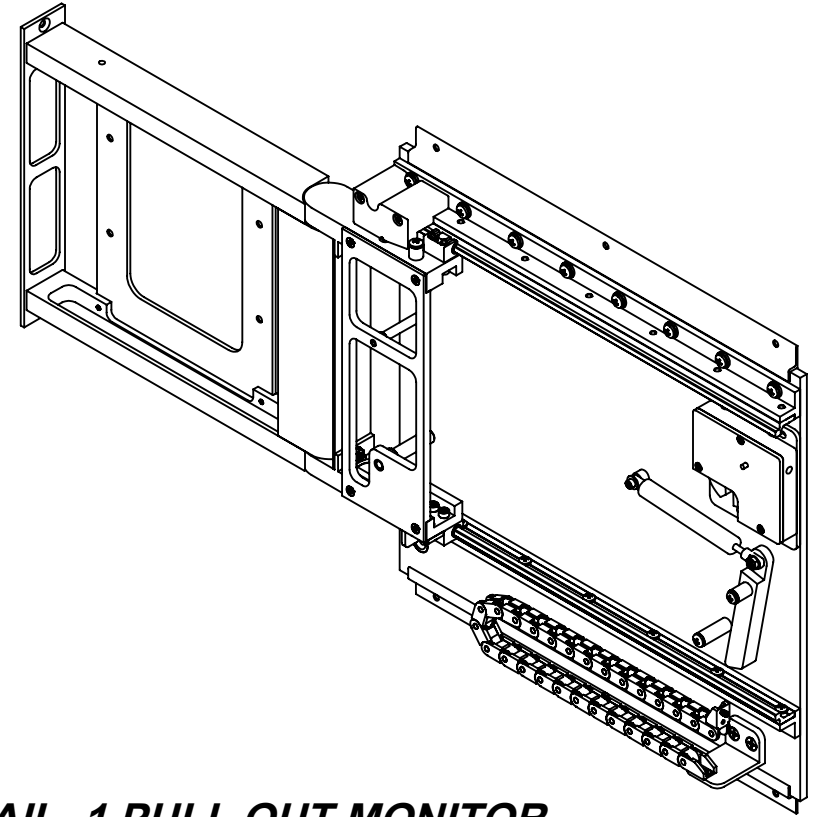

**GENERAL NOTES:  
UNLESS OTHERWISE SPECIFIED**

1. BREAK ALL SHARP CORNERS

△2 PURCHASE FROM IGUS

**DETAIL -1 PULL OUT MONITOR**

UNLESS OTHERWISE SPECIFIED DIMENSIONS ARE IN INCHES			DRAWN BY	MT	DATE	12/12/08	 5362 INDUSTRIAL DRIVE HUNTINGTON BEACH, CA 92649
TOLERANCES ON DECIMALS			CHECKED BY	MH	DATE	12/12/08	
ANGLES			APPROVED	MH	DATE	12/12/08	
.0 ± .1	MACH.	FORMED					
.00 ± .01							
.000 ± .005	±0°30'	±2°					
DO NOT SCALE PRINT BREAK ALL SHARP EDGES							TITLE
ODD DASH NO'S SHOWN NEXT HIGHER CONSECUTIVE EVEN DASH NUMBER OPPOSITE							PULL OUT MONITOR
					SIZE	SCALE	DRAWING NUMBER
					A	1:5	3538-006
							SHEET NO.
							1 OF 5

STEECON CORPORATION PROPRIETARY RIGHTS ARE INCLUDED IN THE INFORMATION DISCLOSED HEREIN. RECIPIENT BY ACCEPTING THIS DOCUMENT AGREES THAT NEITHER THIS DOCUMENT NOR THE INFORMATION DISCLOSED HEREIN NOR ANY PART THEREOF SHALL BE REPRODUCED OR TRANSFERRED TO OTHER DOCUMENTS OR USED OR DISCLOSED TO OTHERS FOR MANUFACTURING OR FOR ANY OTHER PURPOSE EXCEPT AS SPECIFICALLY AUTHORIZED IN WRITING BY STEECON CORPORATION.

FILE:3538-006 PULL OUT MONITOR ASSEMBLY REV A

REV.	DATE	DESCRIPTION
IR	12/12/08	INITIAL RELEASE
A	02/03/10	-3 ADDED

D  
C  
B  
A

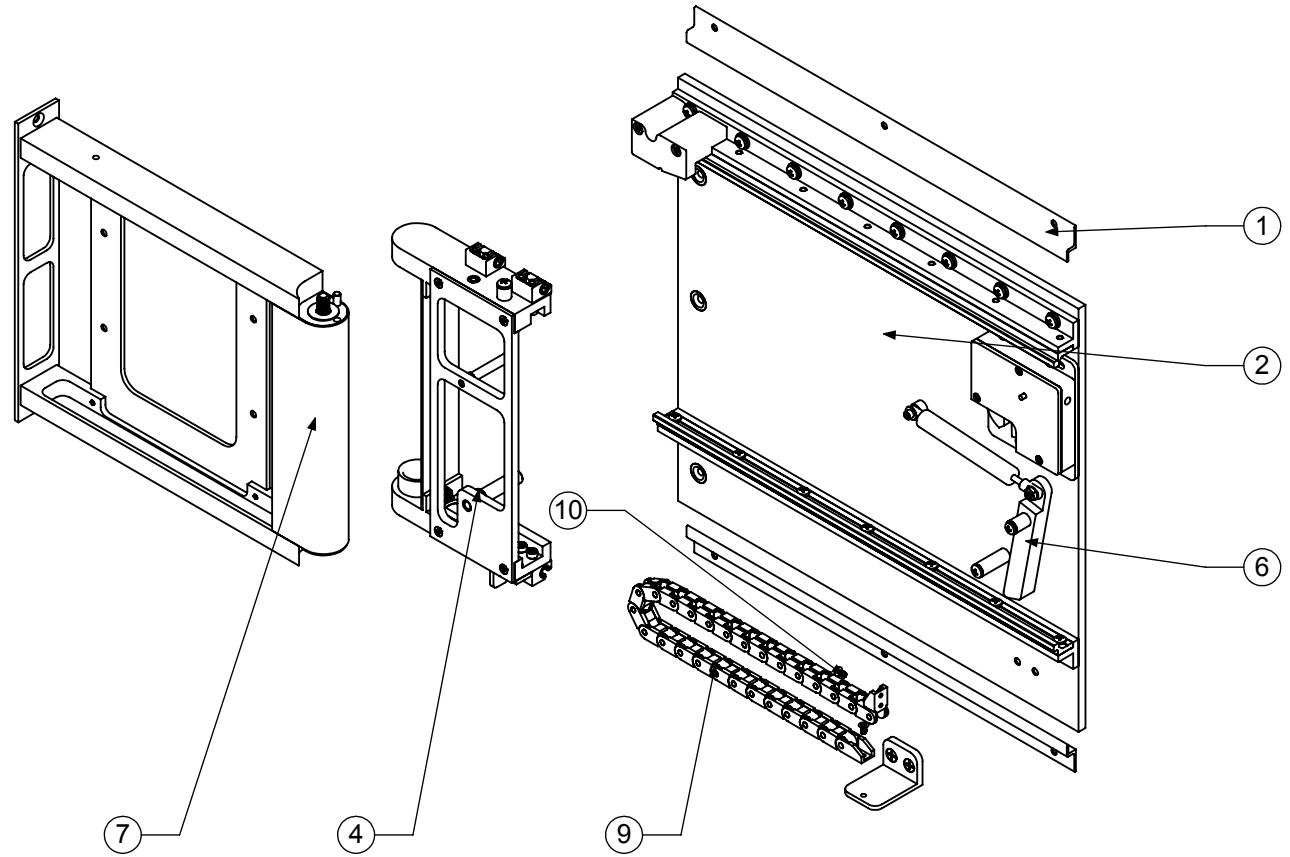

**DETAIL -1 PULL OUT MONITOR**

STEECON CORPORATION PROPRIETARY RIGHTS ARE INCLUDED IN THE INFORMATION DISCLOSED HEREIN. RECIPIENT BY ACCEPTING THIS DOCUMENT AGREES THAT NEITHER THIS DOCUMENT NOR THE INFORMATION DISCLOSED HEREIN NOR ANY PART THEREOF SHALL BE REPRODUCED OR TRANSFERRED TO OTHER DOCUMENTS OR USED OR DISCLOSED TO OTHERS FOR MANUFACTURING OR FOR ANY OTHER PURPOSE EXCEPT AS SPECIFICALLY AUTHORIZED IN WRITING BY STEECON CORPORATION.

UNLESS OTHERWISE SPECIFIED DIMENSIONS ARE IN INCHES			DRAWN BY	MT	DATE	12/12/08	 5362 INDUSTRIAL DRIVE HUNTINGTON BEACH, CA 92649	
TOLERANCES ON DECIMALS			CHECKED BY	MH	DATE	12/12/08		
.0 ± .1	MACH.	FORMED	APPROVED	MH	DATE	12/12/08		
.00 ± .01	±0°30'	±2°						
.000 ± .005			DO NOT SCALE PRINT BREAK ALL SHARP EDGES				TITLE	
ODD DASH NO'S SHOWN NEXT HIGHER CONSECUTIVE EVEN DASH NUMBER OPPOSITE			SIZE				A	TITLE
			SCALE				1:5	TITLE
			DRAWING NUMBER				3538-006	TITLE
			SHEET NO.				2 OF 5	TITLE

8 7 6 5 4 3 2 1

FILE:3538-006 PULL OUT MONITOR ASSEMBLY REV A

REV.	DATE	DESCRIPTION
IR	12/12/08	INITIAL RELEASE
A	02/03/10	-3 ADDED

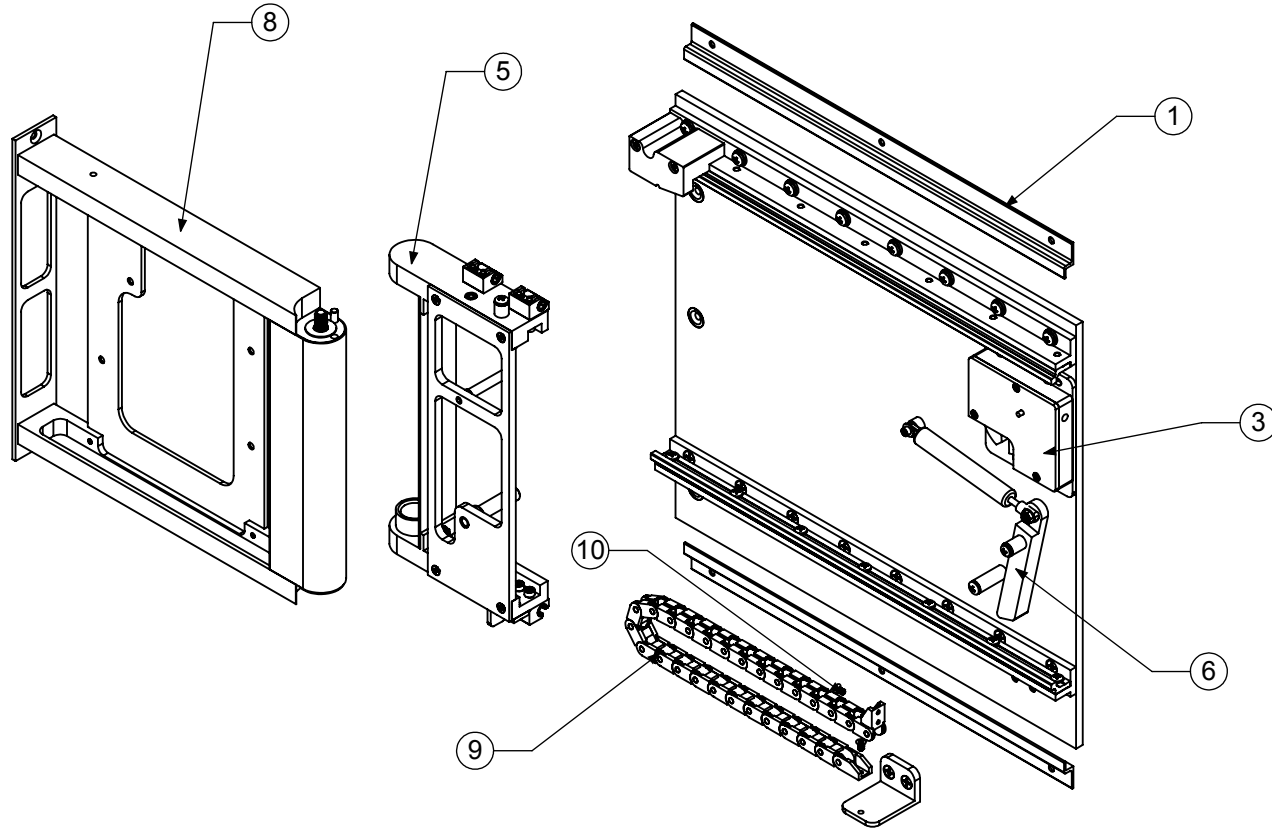

### **DETAIL -3 PULL OUT MONITOR**

STEECON CORPORATION PROPRIETARY RIGHTS ARE INCLUDED IN THE INFORMATION DISCLOSED HEREIN. RECIPIENT BY ACCEPTING THIS DOCUMENT AGREES THAT NEITHER THIS DOCUMENT NOR THE INFORMATION DISCLOSED HEREIN NOR ANY PART THEREOF SHALL BE REPRODUCED OR TRANSFERRED TO OTHER DOCUMENTS OR USED OR DISCLOSED TO OTHERS FOR MANUFACTURING OR FOR ANY OTHER PURPOSE EXCEPT AS SPECIFICALLY AUTHORIZED IN WRITING BY STEECON CORPORATION.

UNLESS OTHERWISE SPECIFIED DIMENSIONS ARE IN INCHES		DRAWN BY	MT	DATE	12/12/08	 5362 INDUSTRIAL DRIVE HUNTINGTON BEACH, CA 92649
TOLERANCES ON DECIMALS		CHECKED BY	MH	DATE	12/12/08	
.0 ± .1	MACH.	APPROVED	MH	DATE	12/12/08	
.00 ± .01	FORMED					
.000 ± .005	±0°30'					TITLE
DO NOT SCALE PRINT BREAK ALL SHARP EDGES						PULL OUT MONITOR
ODD DASH NO'S SHOWN NEXT HIGHER CONSECUTIVE EVEN DASH NUMBER OPPOSITE						DRAWING NUMBER
				SIZE	A	3538-006
				SCALE	1:5	SHEET NO.
						3 OF 5

REV.	DATE	DESCRIPTION
IR	12/12/08	INITIAL RELEASE
A	02/03/10	-3 ADDED

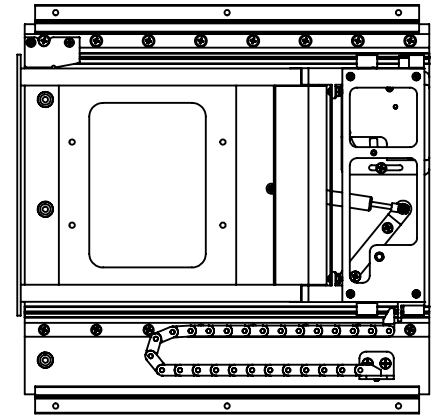
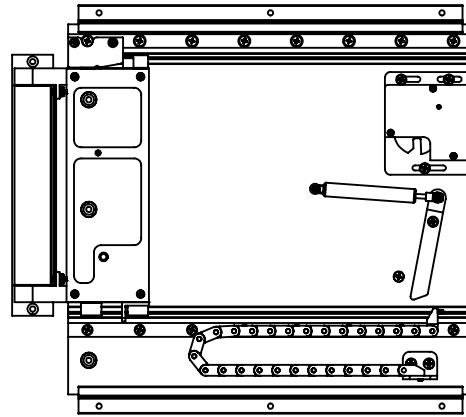
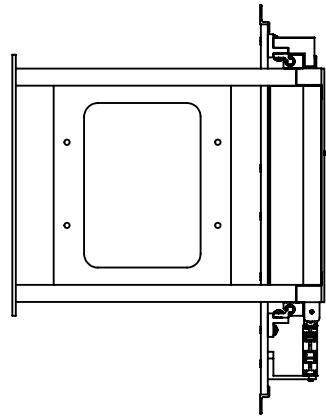
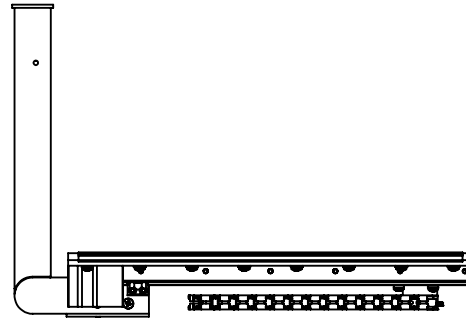

**DETAIL -1 DEPLOYED-ROTATED**

**DETAIL -1 STOWED**

UNLESS OTHERWISE SPECIFIED DIMENSIONS ARE IN INCHES			DRAWN BY	MT	DATE	12/12/08
TOLERANCES ON DECIMALS			CHECKED BY	MH	DATE	12/12/08
ANGLES			APPROVED	MH	DATE	12/12/08
.0 ± .1	MACH.	FORMED				
.00 ± .01	±0°30'	±2°				
.000 ± .005	DO NOT SCALE PRINT BREAK ALL SHARP EDGES					
ODD DASH NO'S SHOWN NEXT HIGHER CONSECUTIVE EVEN DASH NUMBER OPPOSITE			SIZE	A	SCALE	1:7
DRAWING NUMBER			3538-006		SHEET NO. 4 OF 5	



TITLE  
**PULL OUT MONITOR**

STEECON CORPORATION PROPRIETARY RIGHTS ARE INCLUDED IN THE INFORMATION DISCLOSED HEREIN. RECIPIENT BY ACCEPTING THIS DOCUMENT AGREES THAT NEITHER THIS DOCUMENT NOR THE INFORMATION DISCLOSED HEREIN NOR ANY PART THEREOF SHALL BE REPRODUCED OR TRANSFERRED TO OTHER DOCUMENTS OR USED OR DISCLOSED TO OTHERS FOR MANUFACTURING OR FOR ANY OTHER PURPOSE EXCEPT AS SPECIFICALLY AUTHORIZED IN WRITING BY STEECON CORPORATION.

FILE: 3538-006 PULL OUT MONITOR ASSEMBLY

REV.	DATE	DESCRIPTION
IR	12/12/08	INITIAL RELEASE
A	02/03/10	-3 ADDED

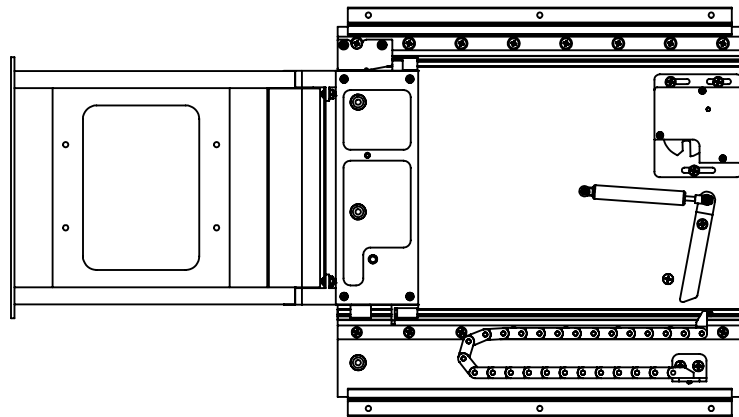

**DETAIL -1 DEPLOYED**

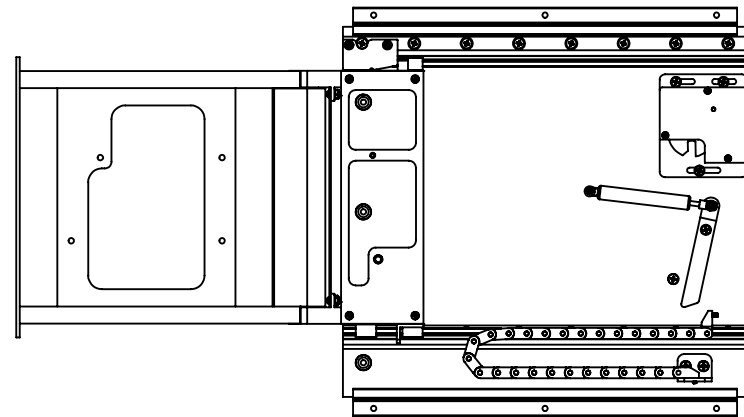

**DETAIL -3 DEPLOYED**

STEECON CORPORATION PROPRIETARY RIGHTS ARE INCLUDED IN THE INFORMATION DISCLOSED HEREIN. RECIPIENT BY ACCEPTING THIS DOCUMENT AGREES THAT NEITHER THIS DOCUMENT NOR THE INFORMATION DISCLOSED HEREIN NOR ANY PART THEREOF SHALL BE REPRODUCED OR TRANSFERRED TO OTHER DOCUMENTS OR USED OR DISCLOSED TO OTHERS FOR MANUFACTURING OR FOR ANY OTHER PURPOSE EXCEPT AS SPECIFICALLY AUTHORIZED IN WRITING BY STEECON CORPORATION.

UNLESS OTHERWISE SPECIFIED DIMENSIONS ARE IN INCHES			DRAWN BY	MT	DATE	12/12/08	 <b>STEECON</b> ENTERPRISES 5362 INDUSTRIAL DRIVE HUNTINGTON BEACH, CA 92649
TOLERANCES ON DECIMALS			CHECKED BY	MH	DATE	12/12/08	
.0 ± .1	MACH.	FORMED	APPROVED	MH	DATE	12/12/08	
.00 ± .01	±0°30'	±2°					
.000 ± .005			DO NOT SCALE PRINT BREAK ALL SHARP EDGES				TITLE
			ODD DASH NO'S SHOWN NEXT HIGHER CONSECUTIVE EVEN DASH NUMBER OPPOSITE				<b>PULL OUT MONITOR</b>
			SIZE	A	SCALE	1:7	DRAWING NUMBER
						<b>3538-006</b>	SHEET NO. 5 OF 5

FILE: 3538-006 PULL OUT MONITOR ASSEMBLY

REV A