

**NOTES**

- 1. PURCHASE FROM MCMASTER CARR
- 2. PARTS SHALL BE PACKAGED AND DELIVERED WITH FINAL ASSEMBLY

REV.	DATE	DESCRIPTION
IR	6/22/08	INITIAL RELEASE

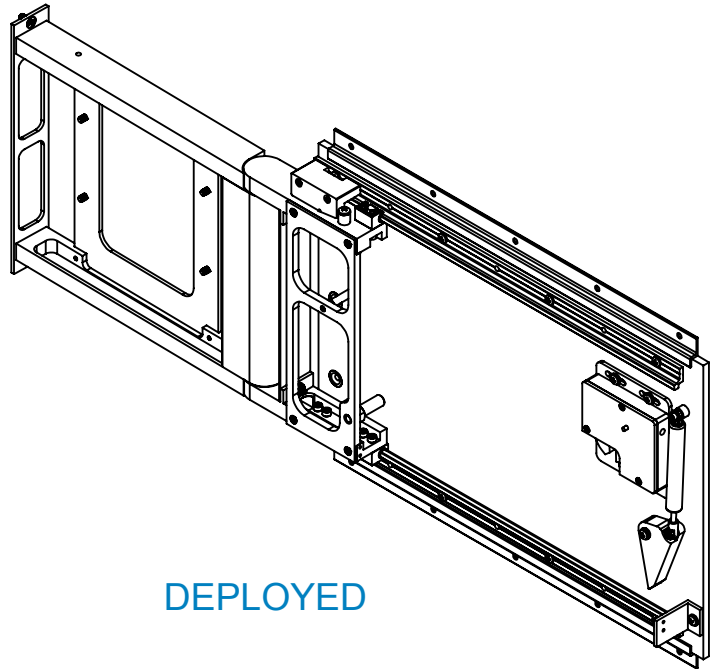

DEPLOYED

2	25	3545158-5	FHMS #10-32, GOLD PLATED	2	
4	24	3545158-4	FHMS #6-32, GOLD PLATED		
2	23	3545158-3	FHMS #4-40, GOLD PLATED		
4	22	3545158-2	FHMS #10-24, GOLD PLATED	2	
2	21	3545158-1	HEX HEAD #6-32, GOLD PLATED		
1	20	3545157-1	MODIFIED RAIL		
1	19	3545156-1	MODIFIED DELRIN WASHER - 1"		
1	18	3545155-1	MODIFIED PTFE FLAT WASHER 3/8"		
1	17	3545153-1	MODIFIED SHOULDER SCREW ,0.25 DIA		
1	16	3545152-1	MODIFIED SHOULDER SCREW ,0.375 DIA		
1	15	3545151-3	COVER PLATE		
1	14	3545150-3	PLATE		
1	13	3545149-3	PANEL END PLATE		
1	12	3545148-1	GAS SHOCK ARM		
1	11	3545147-1	MAIN PANEL ASM		
1	10	3545146-1	GUIDE		
1	9	3545145-1	SHEAR PLATE		
1	8	3545144-3	BACK MOUNTING PLATE		
1	7	3545143-3	BOTTOM ARM		
1	6	3545142-3	BOTTOM PIVOT		
1	5	3545141-3	TOP ARM		
1	4	3545140-3	TOP PIVOT		
1	3	3528161-1	TOUCH LATCH ASSEMBLY		
2	2	3502295-2	RETAINER		
1	1	3408A77	BALL NOSE PLUNGER 5/16"-18 X 0.578"	1	
-1	ITEM	PART NUMBER	Description	NOTE	SPEC

UNLESS OTHERWISE SPECIFIED DIMENSIONS ARE IN INCHES		DRAWN BY	J CILEO	DATE	6/22/08	 STEECON ENTERPRISES 5362 INDUSTRIAL DRIVE HUNTINGTON BEACH, CA 92649
TOLERANCES ON DECIMALS		CHECKED BY	M HANSON	DATE	6/22/08	
ANGLES		APPROVED	M HANSON	DATE	6/22/08	
.0 ± .1	MACH.	FORMED				TITLE
.00 ± .01						<b>SLIDE OUT MONITOR</b>
.000 ± .005	±0°30'	±2°				DRAWING NUMBER
DO NOT SCALE PRINT BREAK ALL SHARP EDGES				SIZE	A	SCALE
ODD DASH NO'S SHOWN NEXT HIGHER CONSECUTIVE EVEN DASH NUMBER OPPOSITE					1:6	3538-003
						SHEET NO.
						1 OF 5

STEECON CORPORATION PROPRIETARY RIGHTS ARE INCLUDED IN THE INFORMATION DISCLOSED HEREIN. RECIPIENT BY ACCEPTING THIS DOCUMENT AGREES THAT NEITHER THIS DOCUMENT NOR THE INFORMATION DISCLOSED HEREIN NOR ANY PART THEREOF SHALL BE REPRODUCED OR TRANSFERRED TO OTHER DOCUMENTS OR USED OR DISCLOSED TO OTHERS FOR MANUFACTURING OR FOR ANY OTHER PURPOSE EXCEPT AS SPECIFICALLY AUTHORIZED IN WRITING BY STEECON CORPORATION.

REV.	DATE	DESCRIPTION
IR	6/22/08	INITIAL RELEASE

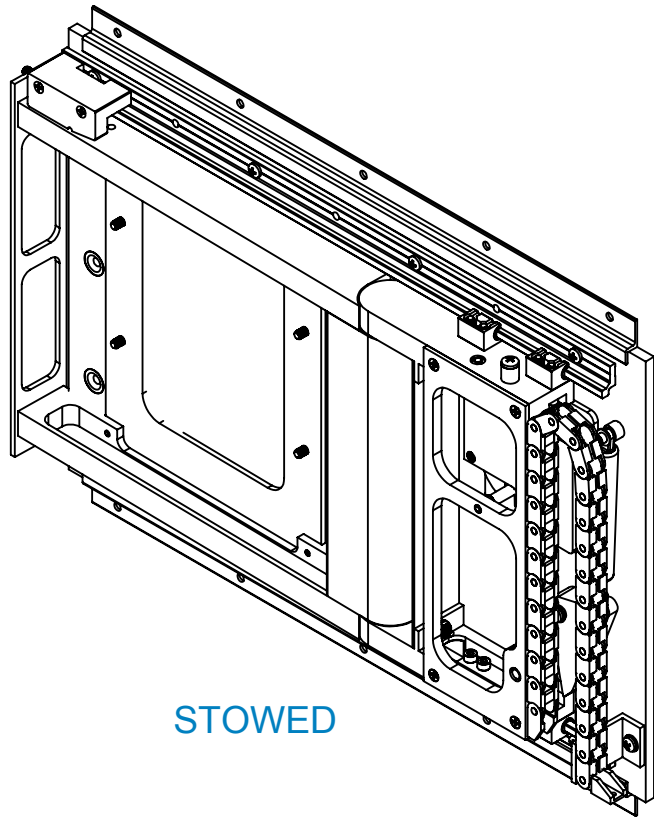

STOWED

1	53	WSQ-06	RAIL		
4	52	WJ200QM-01-06	GUIDE BLOCK		
1	51	NAS620-C6	WASHER, REDUCED O.D. - NO 6		
1	50	MS51971-2	HEX NUT - 5/16"-18		
1	49	MS27039-1-09	PHCS #10-32 X 0.593		
1	48	MS27039-0811	PHCS #8-32 X 0.718		
12	47	MS27039-0805	PHCS #8-32 X 0.343		
2	46	MS24693-C33	FLAT HEAD, 100 DEG, #6-32 X 1.125		
1	45	MS24693-C29	FLAT HEAD, 100 DEG, #6-32 X 0.625		
8	44	MS24693-C25	FLAT HEAD, 100 DEG, #6-32 X 0.3125		
1	43	MS16995-19	SHCS #6-32 X 0.625		
1	42	MS16555-641	DOWEL PIN, 0.1875 DIA X 0.75 LG		
1	41	E04_07_018_0_01	IGUS CABLE GUIDE		
5	40	AN960-C8	FLAT WASHER - NO. 8		
3	39	AN960-C6	FLAT WASHER - NO. 6		
3	38	AN364-632	STOP NUT - #6-32 NC-2B		
1	37	9712K72	BELLEVILLE WASHER, ID 0.38, LD 433 LBS	1	
1	36	95630A245	PTFE FLAT WASHER 3/8", -0.031 THK	1	
1	35	9417K331	GAS SPRING		
8	34	91290A168	SHCS M4 X 20 MM	1	
1	33	91259A621	SHOULDER SCREW 3/8 DIA X 0.625	1	
2	32	91255A105	BHCS #4-40 X 0.1875		
1	31	90730A011	HEX NUT - #10-24	1	
1	30	90309A701	UNTHREADED SPACER FOR #8	1	
1	29	90309A154	UNTHREADED SPACER FOR #6	1	
1	28	90309A141	UNTHREADED SPACER FOR #10	1	
1	27	3545160-3	PIVOT SHROUD		
1	26	3545159-1	CABLE GUIDE BRACKET		
-1	ITEM	PART NUMBER	Description	NOTE	SPEC

UNLESS OTHERWISE SPECIFIED DIMENSIONS ARE IN INCHES			DRAWN BY	J CILEO	DATE	6/22/08	 STEECON ENTERPRISES 5362 INDUSTRIAL DRIVE HUNTINGTON BEACH, CA 92649
TOLERANCES ON DECIMALS			CHECKED BY	M HANSON	DATE	6/22/08	
ANGLES			APPROVED	M HANSON	DATE	6/22/08	
.0 ± .1	MACH.	FORMED	Q.C.		DATE		
.00 ± .01					DATE		TITLE <b>SLIDE OUT MONITOR</b>
.000 ± .005	±0°30'	±2°	CUSTOMER		DATE		
DO NOT SCALE PRINT BREAK ALL SHARP EDGES					DATE		DRAWING NUMBER <b>3538-003</b>
ODD DASH NO'S SHOWN NEXT HIGHER CONSECUTIVE EVEN DASH NUMBER OPPOSITE					DATE		
					SIZE	A	
					SCALE	1:4	

STEECON CORPORATION PROPRIETARY RIGHTS ARE INCLUDED IN THE INFORMATION DISCLOSED HEREIN. RECIPIENT BY ACCEPTING THIS DOCUMENT AGREES THAT NEITHER THIS DOCUMENT NOR THE INFORMATION DISCLOSED HEREIN NOR ANY PART THEREOF SHALL BE REPRODUCED OR TRANSFERRED TO OTHER DOCUMENTS OR USED OR DISCLOSED TO OTHERS FOR MANUFACTURING OR FOR ANY OTHER PURPOSE EXCEPT AS SPECIFICALLY AUTHORIZED IN WRITING BY STEECON CORPORATION.

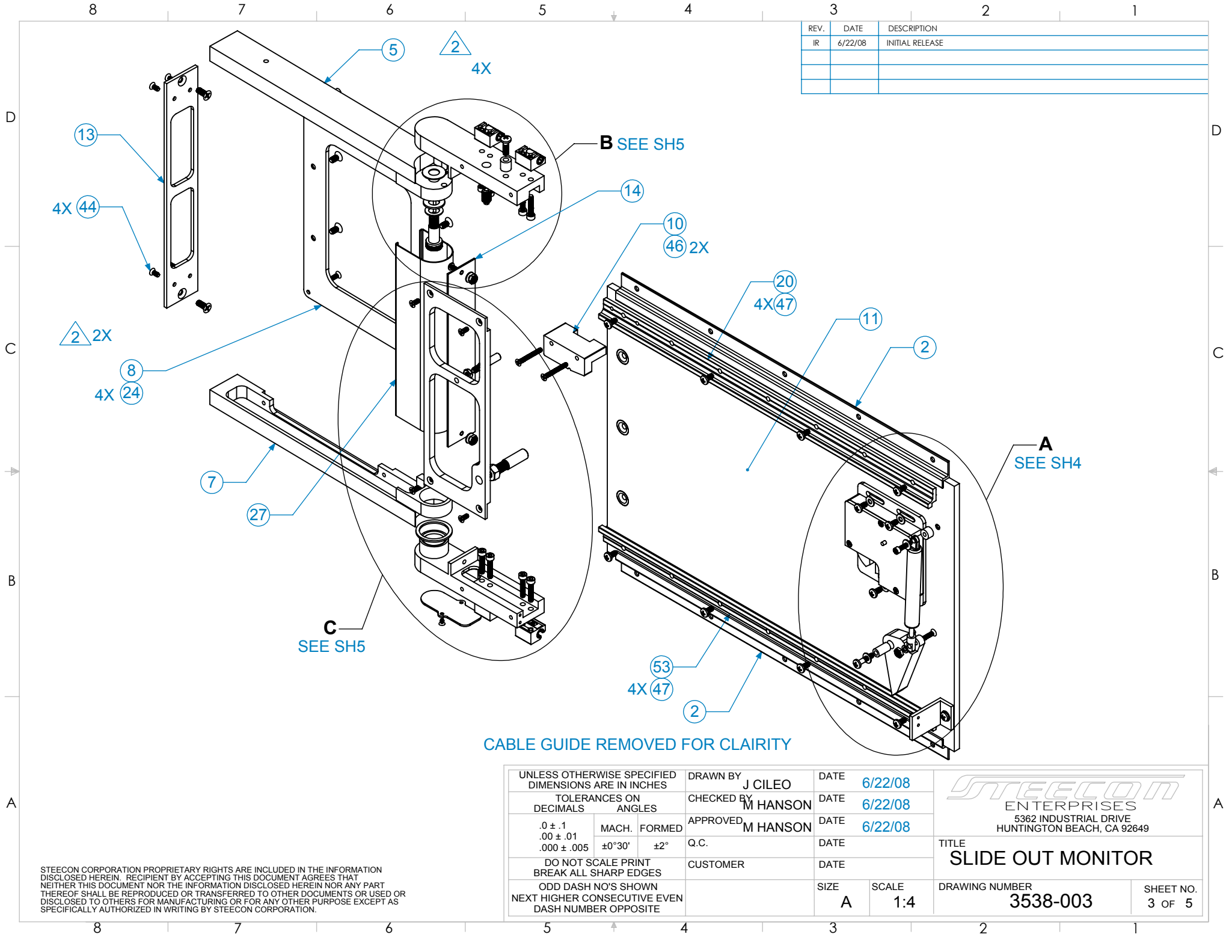

REV.	DATE	DESCRIPTION
IR	6/22/08	INITIAL RELEASE

CABLE GUIDE REMOVED FOR CLAIRTY

UNLESS OTHERWISE SPECIFIED DIMENSIONS ARE IN INCHES		DRAWN BY	J CILEO	DATE	6/22/08	 STEECON ENTERPRISES 5362 INDUSTRIAL DRIVE HUNTINGTON BEACH, CA 92649	
TOLERANCES ON DECIMALS		CHECKED BY	M HANSON	DATE	6/22/08		
.0 ± .1	MACH.	APPROVED	M HANSON	DATE	6/22/08		
.00 ± .01	FORMED	Q.C.		DATE			
.000 ± .005	±0°30'	±2°	CUSTOMER	DATE		TITLE	SLIDE OUT MONITOR
DO NOT SCALE PRINT BREAK ALL SHARP EDGES						SIZE	A
ODD DASH NO'S SHOWN NEXT HIGHER CONSECUTIVE EVEN DASH NUMBER OPPOSITE						SCALE	1:4
						DRAWING NUMBER	3538-003
						SHEET NO.	3 OF 5

STEECON CORPORATION PROPRIETARY RIGHTS ARE INCLUDED IN THE INFORMATION DISCLOSED HEREIN. RECIPIENT BY ACCEPTING THIS DOCUMENT AGREES THAT NEITHER THIS DOCUMENT NOR THE INFORMATION DISCLOSED HEREIN NOR ANY PART THEREOF SHALL BE REPRODUCED OR TRANSFERRED TO OTHER DOCUMENTS OR USED OR DISCLOSED TO OTHERS FOR MANUFACTURING OR FOR ANY OTHER PURPOSE EXCEPT AS SPECIFICALLY AUTHORIZED IN WRITING BY STEECON CORPORATION.

8 7 6 5 4 3 2 1

REV.	DATE	DESCRIPTION
IR	6/22/08	INITIAL RELEASE

D  
C  
B  
A

D  
C  
B  
A

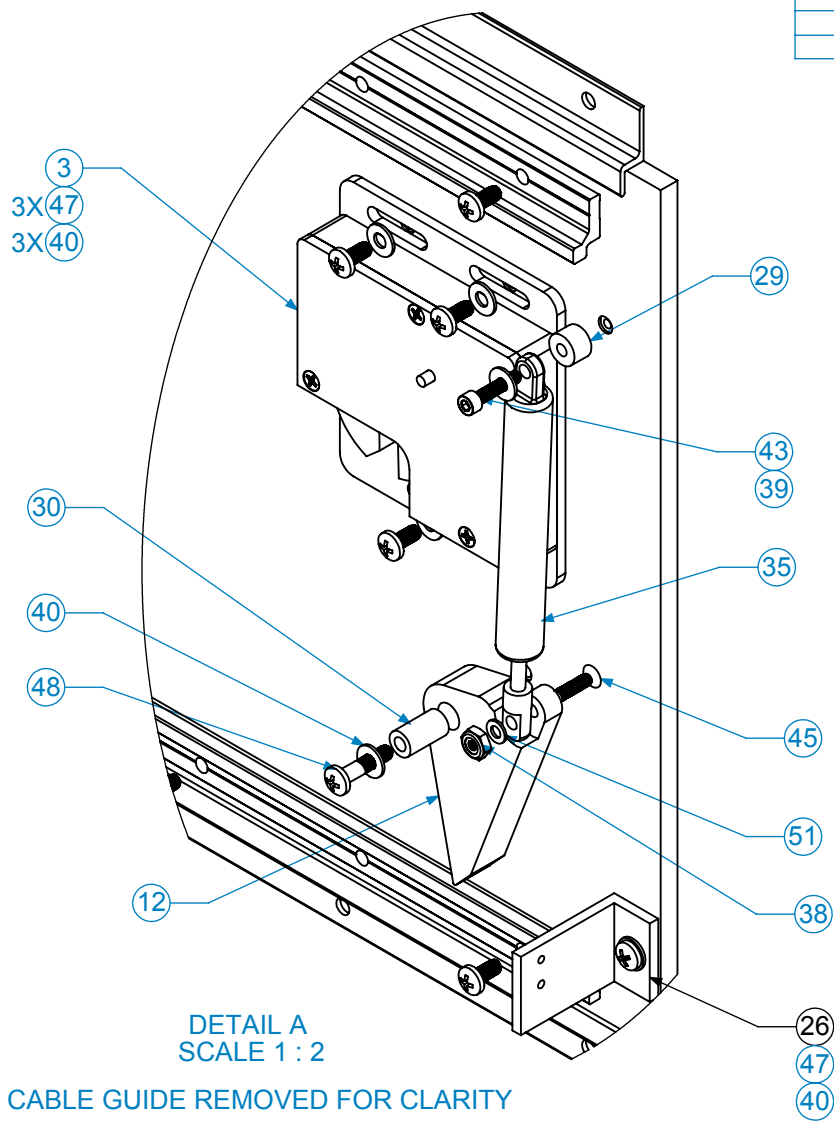

DETAIL A  
SCALE 1 : 2  
CABLE GUIDE REMOVED FOR CLARITY

UNLESS OTHERWISE SPECIFIED DIMENSIONS ARE IN INCHES			DRAWN BY	J CILEO	DATE	6/22/08	 5362 INDUSTRIAL DRIVE HUNTINGTON BEACH, CA 92649	
TOLERANCES ON DECIMALS			CHECKED BY	M HANSON	DATE	6/22/08		
MACH. FORMED			APPROVED	M HANSON	DATE	6/22/08		
.0 ± .1			Q.C.		DATE			
.00 ± .01	±0°30'	±2°	CUSTOMER		DATE		TITLE	SLIDE OUT MONITOR
DO NOT SCALE PRINT BREAK ALL SHARP EDGES					DATE		DRAWING NUMBER	3538-003
ODD DASH NO'S SHOWN NEXT HIGHER CONSECUTIVE EVEN DASH NUMBER OPPOSITE					DATE		SIZE	A
					SCALE	1:4	SHEET NO.	4 OF 5

STEECON CORPORATION PROPRIETARY RIGHTS ARE INCLUDED IN THE INFORMATION DISCLOSED HEREIN. RECIPIENT BY ACCEPTING THIS DOCUMENT AGREES THAT NEITHER THIS DOCUMENT NOR THE INFORMATION DISCLOSED HEREIN NOR ANY PART THEREOF SHALL BE REPRODUCED OR TRANSFERRED TO OTHER DOCUMENTS OR USED OR DISCLOSED TO OTHERS FOR MANUFACTURING OR FOR ANY OTHER PURPOSE EXCEPT AS SPECIFICALLY AUTHORIZED IN WRITING BY STEECON CORPORATION.

8 7 6 5 4 3 2 1

REV.	DATE	DESCRIPTION
IR	6/22/08	INITIAL RELEASE

D

C

B

A

D

C

B

A

DETAIL C  
SCALE 1 : 2

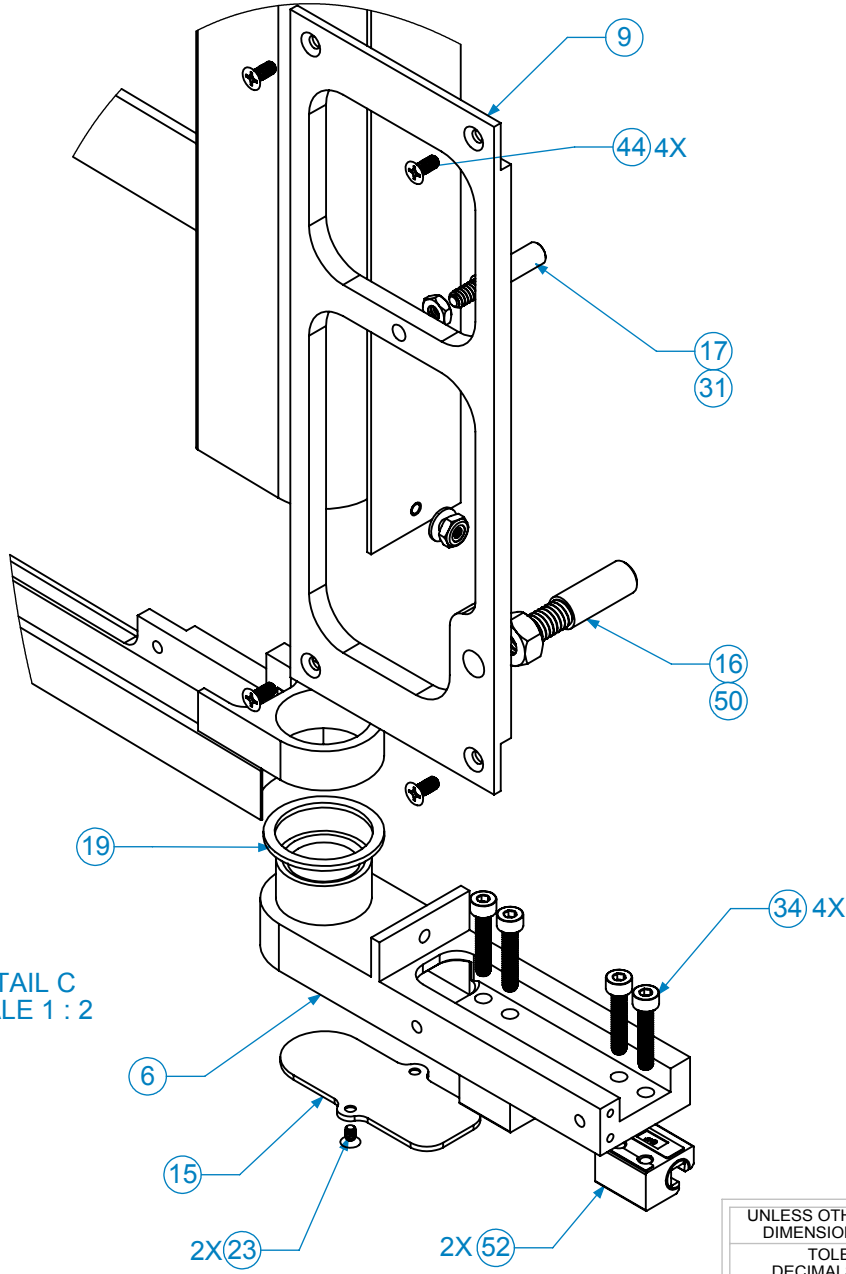

DETAIL B  
SCALE 1 : 2

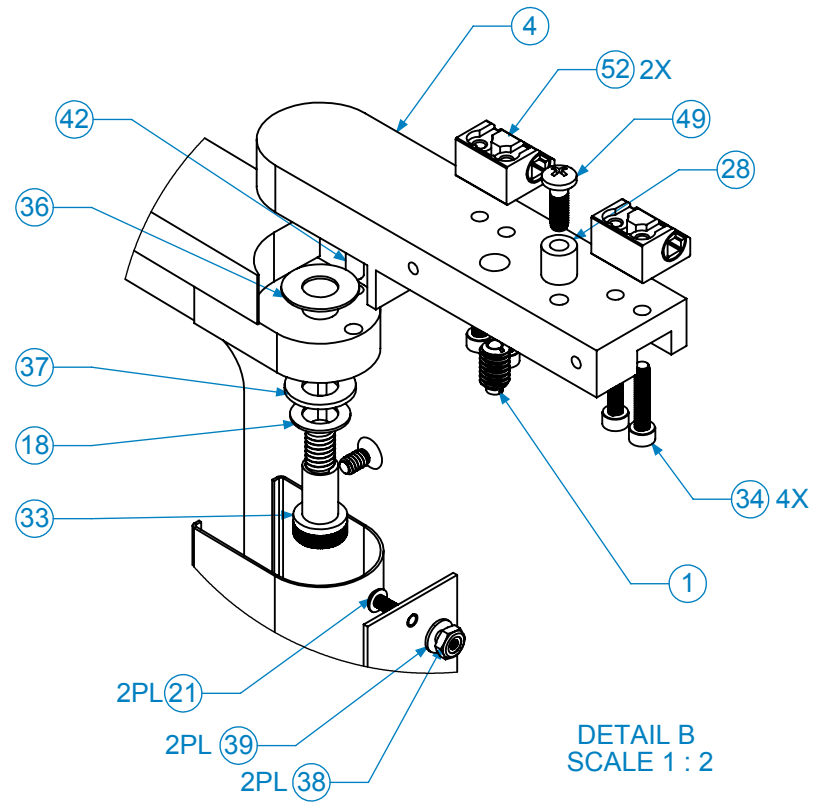

STEECON CORPORATION PROPRIETARY RIGHTS ARE INCLUDED IN THE INFORMATION DISCLOSED HEREIN. RECIPIENT BY ACCEPTING THIS DOCUMENT AGREES THAT NEITHER THIS DOCUMENT NOR THE INFORMATION DISCLOSED HEREIN NOR ANY PART THEREOF SHALL BE REPRODUCED OR TRANSFERRED TO OTHER DOCUMENTS OR USED OR DISCLOSED TO OTHERS FOR MANUFACTURING OR FOR ANY OTHER PURPOSE EXCEPT AS SPECIFICALLY AUTHORIZED IN WRITING BY STEECON CORPORATION.

UNLESS OTHERWISE SPECIFIED DIMENSIONS ARE IN INCHES			DRAWN BY J CILEO		DATE 6/22/08		 5362 INDUSTRIAL DRIVE HUNTINGTON BEACH, CA 92649	
TOLERANCES ON DECIMALS			CHECKED BY M HANSON		DATE 6/22/08			
ANGLES			APPROVED M HANSON		DATE 6/22/08		TITLE	
.0 ± .1	MACH.	FORMED	Q.C.		DATE		SLIDE OUT MONITOR	
.00 ± .01	±0°30'	±2°	CUSTOMER		DATE		DRAWING NUMBER	
.000 ± .005							3538-003	
DO NOT SCALE PRINT BREAK ALL SHARP EDGES					SIZE		SHEET NO.	
ODD DASH NO'S SHOWN NEXT HIGHER CONSECUTIVE EVEN DASH NUMBER OPPOSITE					A		5 OF 5	
					SCALE			
					1:4			

8 7 6 5 4 3 2 1