

REV.	DATE	DESCRIPTION
IR	4/13/07	INITIAL RELEASE

GENERAL NOTES:  
UNLESS OTHERWISE SPECIFIED  
1. BREAK ALL SHARP CORNERS

② PURCHASE FROM MCMASTER CARR

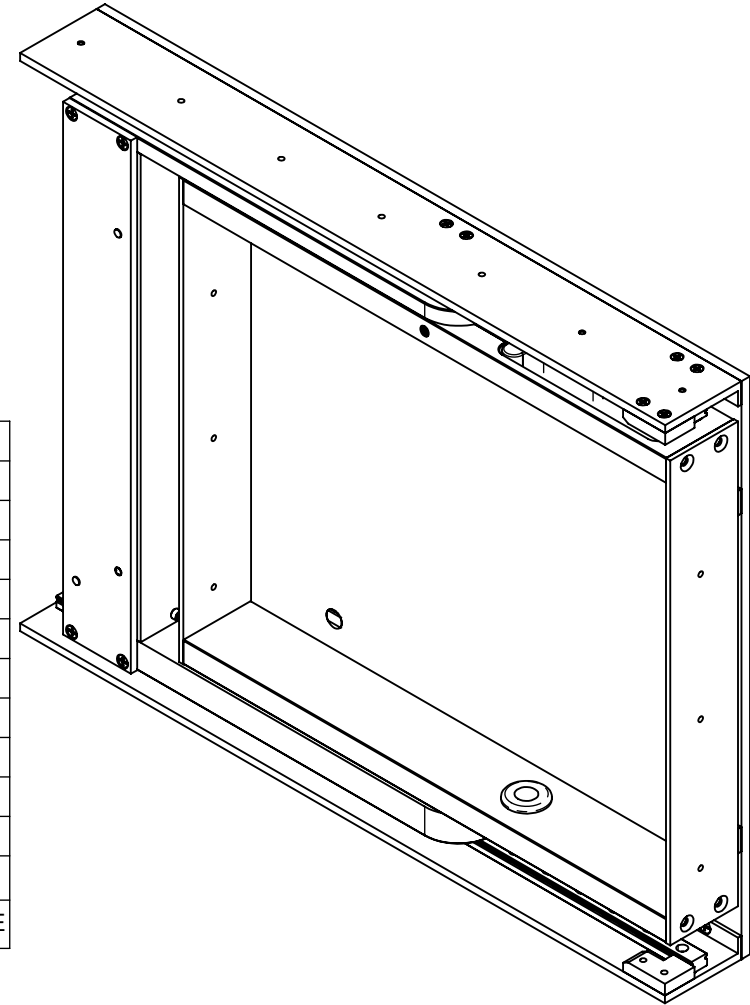

1	⑫	3528161-1	TOUCH LATCH ASSEMBLY			
3	⑨	AN960-10	10-32 WASHER			
3	⑧	MS35207-260	10-32 x .312 Pan Cross Screw		②	
2	⑦	95630A219	.75" X .325" WASHER-PTFE		②	
1	⑥	92949A563	1/4-28 X .625 BUTTON SHCS		②	
1	⑤	91253A307	1/4-28 X .75 FLAT HEAD SHCS			
1	④	3528353-1	MONITOR PIVOT ARM ASSEMBLY			
1	②	3528352-1	PIVOT ASSEMBLY			
1	①	3528351-1	MOUNT ASSEMBLY			
	-					
	-					
	-	-1	<b>SLIDE OUT MONITOR ASSEMBLY-15"</b>			
-1	QTY	ITEM	PartNo	Description	STOCK SIZE	SPEC ZONE

UNLESS OTHERWISE SPECIFIED DIMENSIONS ARE IN INCHES			DRAWN BY	MH	DATE	4/13/07	 5362 INDUSTRIAL DRIVE HUNTINGTON BEACH, CA 92649	
TOLERANCES ON DECIMALS			CHECKED BY	C. OLSON	DATE	4/13/07		
ANGLES			APPROVED	C. STEEL	DATE	4/13/07		
.0 ± .1	MACH.	FORMED	Q.C.		DATE			
.00 ± .03	±0°30'	±2°	CUSTOMER		DATE		TITLE	<b>SLIDE OUT MONITOR ASSEMBLY-15"</b>
.000 ± .010					DATE		DRAWING NUMBER	<b>3538-002-1</b>
DO NOT SCALE PRINT BREAK ALL SHARP EDGES					DATE		SHEET NO.	<b>1 OF 2</b>
ODD DASH NO'S SHOWN NEXT HIGHER CONSECUTIVE EVEN DASH NUMBER OPPOSITE					DATE			
			SIZE	A	SCALE	1:4		

STEECON CORPORATION PROPRIETARY RIGHTS ARE INCLUDED IN THE INFORMATION DISCLOSED HEREIN. RECIPIENT BY ACCEPTING THIS DOCUMENT AGREES THAT NEITHER THIS DOCUMENT NOR THE INFORMATION DISCLOSED HEREIN NOR ANY PART THEREOF SHALL BE REPRODUCED OR TRANSFERRED TO OTHER DOCUMENTS OR USED OR DISCLOSED TO OTHERS FOR MANUFACTURING OR FOR ANY OTHER PURPOSE EXCEPT AS SPECIFICALLY AUTHORIZED IN WRITING BY STEECON CORPORATION.

REV.	DATE	DESCRIPTION
IR	4/13/07	INITIAL RELEASE

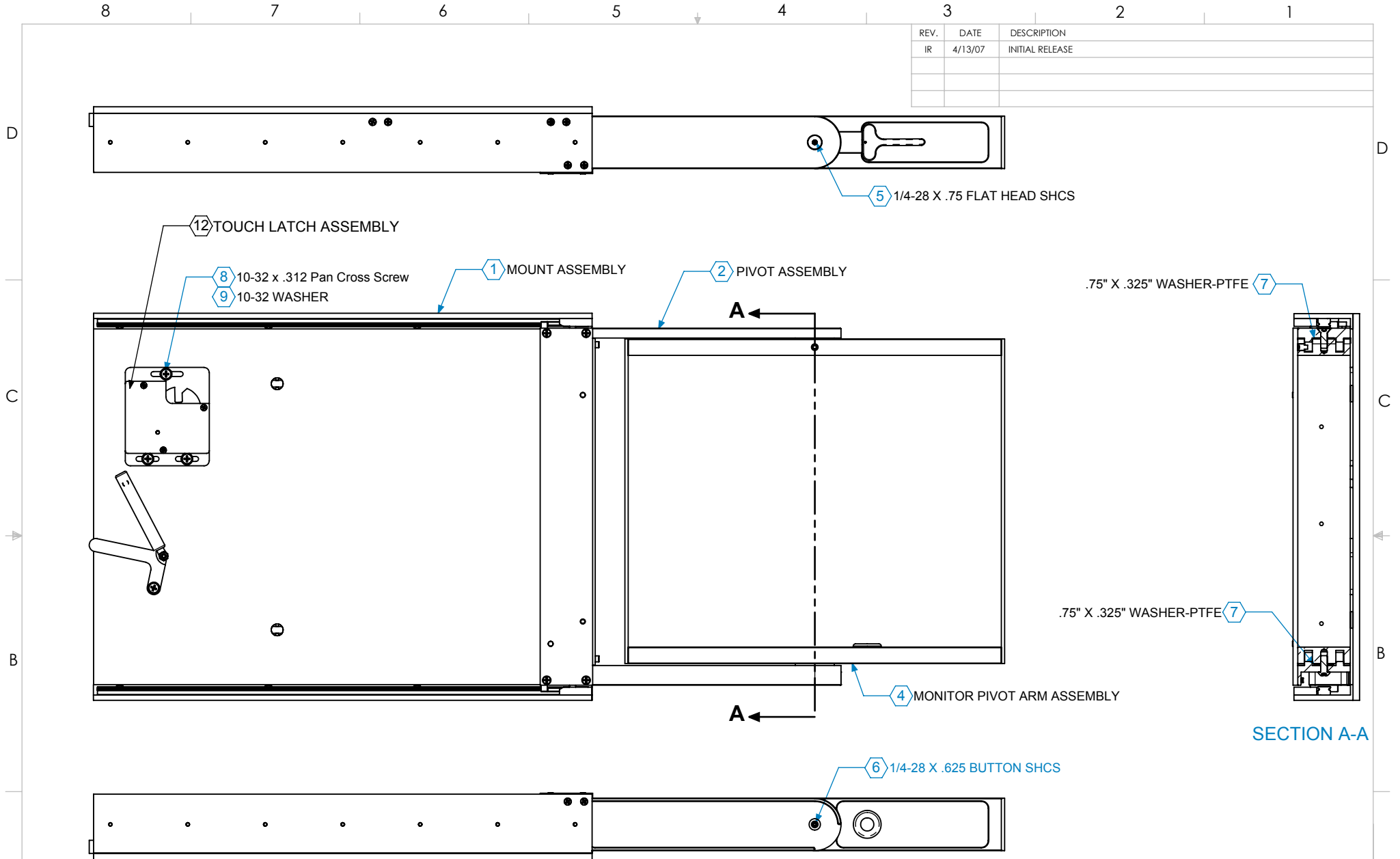

UNLESS OTHERWISE SPECIFIED DIMENSIONS ARE IN INCHES			DRAWN BY	MH	DATE	4/13/07
TOLERANCES ON DECIMALS			CHECKED BY	C. OLSON	DATE	4/13/07
.0 ± .1	MACH.	FORMED	APPROVED	C. STEEL	DATE	4/13/07
.00 ± .03	±0°30'	±2°	Q.C.		DATE	
.000 ± .010			CUSTOMER		DATE	
DO NOT SCALE PRINT BREAK ALL SHARP EDGES					SIZE	A
ODD DASH NO'S SHOWN NEXT HIGHER CONSECUTIVE EVEN DASH NUMBER OPPOSITE					SCALE	1:5

**STEECON**  
ENTERPRISES  
5362 INDUSTRIAL DRIVE  
HUNTINGTON BEACH, CA 92649

TITLE **SLIDE OUT MONITOR ASSEMBLY**

DRAWING NUMBER **3538-002-1** SHEET NO. **2 OF 2**

STEECON CORPORATION PROPRIETARY RIGHTS ARE INCLUDED IN THE INFORMATION DISCLOSED HEREIN. RECIPIENT BY ACCEPTING THIS DOCUMENT AGREES THAT NEITHER THIS DOCUMENT NOR THE INFORMATION DISCLOSED HEREIN NOR ANY PART THEREOF SHALL BE REPRODUCED OR TRANSFERRED TO OTHER DOCUMENTS OR USED OR DISCLOSED TO OTHERS FOR MANUFACTURING OR FOR ANY OTHER PURPOSE EXCEPT AS SPECIFICALLY AUTHORIZED IN WRITING BY STEECON CORPORATION.